

## Big Enough?

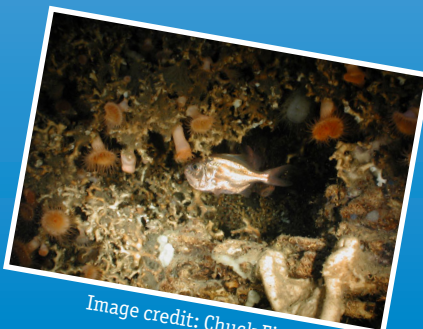
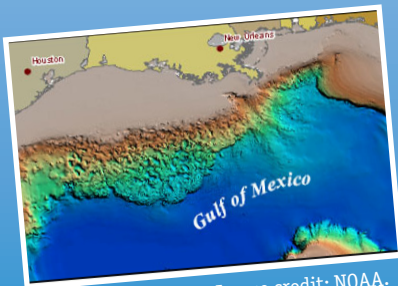
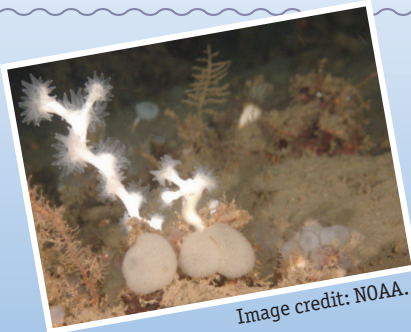

Image captions on Page 2.

# lesson plan

### Focus

Density and buoyancy

### Grade Level

5-6 (Physical Science)

### Focus Question

What factors affect the density and buoyancy of objects in water, and how can these factors be used to design an object that will have a specified buoyancy?

### Learning Objectives

- ✳ Students will be able to describe the factors and variations in those factors that affect the density and buoyancy of objects in water.
- ✳ Students will be able to determine the density of objects.
- ✳ Students will be able to design an object that will have a specified buoyancy when immersed in water.

### Materials

- ✳ Copies of "Density and Buoyancy Inquiry Guide;" one copy for each student group
- ✳ 100 ml graduated cylinder; one for each student group
- ✳ Sink or large containers for waste water
- ✳ Faucet or large container of water with a spigot or siphon to allow controlled dispensing
- ✳ Small objects that will fit into the 100 ml graduated cylinders, such as washers or nuts, small pieces of wood, rocks, pieces of modeling clay, corks, etc.; each student group should have a collection of at least four objects including some that will sink and others that will float
- ✳ Triple beam balance; one balance may be shared by several groups
- ✳ Stiff wire approximately 3 inches long or a straightened paper clip; one for each student group

### Audio-Visual Materials

- 📺 None

### Teaching Time

One or two 45-minute class periods

## Seating Arrangement

Groups of two to four students

## Maximum Number of Students

32

## Key Words

Density  
Buoyancy  
Volume  
Mass

## Background Information

Deepwater coral ecosystems on hard substrates in the Gulf of Mexico are often found in locations where hydrocarbons are seeping through the seafloor. Hydrocarbon seeps may indicate the presence of undiscovered petroleum deposits, and make these locations potential sites for exploratory drilling and possible development of offshore oil wells. Responsibility for managing exploration and development of mineral resources on the Nation's outer continental shelf is a central mission of the U.S. Department of the Interior's Minerals Management Service (MMS). Besides managing the revenues from mineral resources, an integral part of this mission is to protect unique and sensitive environments where these resources are found.

For the past three years, NOAA's Office of Ocean Exploration and Research (OER) has collaborated with MMS on a series of expeditions to locate and explore deep-sea chemosynthetic communities in the Gulf of Mexico. These communities not only indicate the potential presence of hydrocarbons, but are also unique ecosystems whose importance is presently unknown. To protect these ecosystems from negative impacts associated with exploration and extraction of fossil fuels, MMS has developed rules that require the oil and gas industry to avoid any areas where geophysical survey data show that high-density chemosynthetic communities are likely to occur. Similar rules have been adopted to protect archeological sites and historic shipwrecks.

OER-sponsored expeditions in 2006, 2007, and 2008 were focused on discovering sea floor communities near seeping hydrocarbons on hard bottom in the deep Gulf of Mexico; detailed sampling and mapping at selected sites; studying relationships between coral communities on artificial and natural substrates; and gaining a better understanding of processes that control the occurrence and distribution of these communities. The *Lophelia II 2009: Deepwater Coral Expedition: Reefs, Rigs, and Wrecks* will take place aboard the NOAA Ship *Ronald H. Brown*, and is directed toward exploring deepwater natural and artificial hard bottom habitats in the northern Gulf of Mexico with emphasis on coral

---

### Images from Page 1 top to bottom:

*Lophelia pertusa* colony with polyps extended.

[http://oceanexplorer.noaa.gov/explorations/08lophelia/logs/sept24/media/green\\_canyon\\_lophelia.html](http://oceanexplorer.noaa.gov/explorations/08lophelia/logs/sept24/media/green_canyon_lophelia.html)

The ROV from SeaView Systems, Inc., is prepared for launch.

[http://oceanexplorer.noaa.gov/explorations/08lophelia/logs/sept20/media/rov\\_prep.html](http://oceanexplorer.noaa.gov/explorations/08lophelia/logs/sept20/media/rov_prep.html)

Multibeam bathymetry allows terrain models to be created for large areas of the seafloor.

[http://oceanexplorer.noaa.gov/explorations/08lophelia/logs/sept21/media/gomex\\_multibeam.html](http://oceanexplorer.noaa.gov/explorations/08lophelia/logs/sept21/media/gomex_multibeam.html)

*Lophelia pertusa* create habitat for a number of other species at a site in Green Canyon.

[http://oceanexplorer.noaa.gov/explorations/08lophelia/logs/sept24/media/green\\_canyon\\_lophelia.html](http://oceanexplorer.noaa.gov/explorations/08lophelia/logs/sept24/media/green_canyon_lophelia.html)

**Figure 1:**  
**Mooring System**

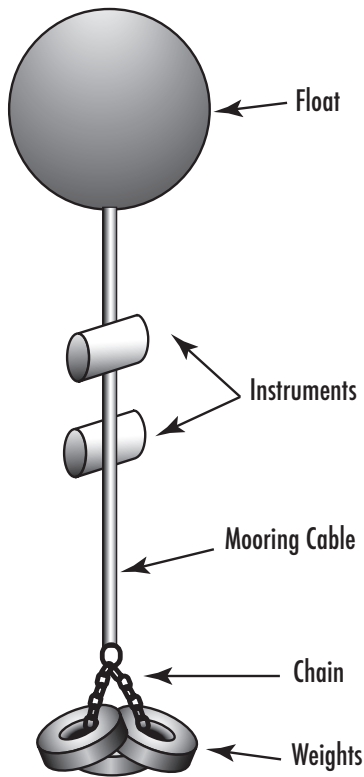

communities, as well as archeological studies of selected shipwrecks in the same region. Expedition scientists will:

- Make collections of *Lophelia*, other corals, and associated organisms from deepwater reefs;
- Collect quantitative digital imagery of characterization of deepwater reef sites and communities;
- Conduct archeological/biological investigations on deep water shipwrecks.
- Deploy instruments to measure currents and sedimentation in several sites for a period of approximately one year.

Instruments for long-term measurements of currents and sedimentation will be attached to a mooring system that will keep these instruments in a fixed location at a specific depth. Because the sampling sites are offshore and in deep water (400 m to 1500 m), the mooring system must be heavy enough and strong enough to withstand strong ocean currents, and also must have a float with sufficient buoyancy to keep the instruments and mooring cable suspended above the seafloor. Figure 1 shows the main parts of the mooring system.

In this lesson, students will determine the density and buoyancy of various objects, and will use their knowledge of buoyancy principles to design a float that would be capable of providing a specified buoyancy for a hypothetical mooring system.

### Learning Procedure

1. To prepare for this lesson:
  - Review introductory essays for the *Lophelia* II 2009: Deepwater Coral Expedition: Reefs, Rigs, and Wrecks at <http://oceanexplorer.noaa.gov/explorations/09lophelia/welcome.html>;
  - Review procedures and questions on the "Density and Buoyancy Inquiry Guide;" and
  - Assemble collections of objects whose density and buoyancy are to be determined
2. Briefly introduce the *Lophelia* II 2009: Deepwater Coral Expedition: Reefs, Rigs, and Wrecks and describe deepwater coral communities. You may want to show images from [http://oceanexplorer.noaa.gov/gallery/livingocean/livingocean\\_coral.html](http://oceanexplorer.noaa.gov/gallery/livingocean/livingocean_coral.html). Tell students that while deepwater coral reefs were discovered in the Gulf of Mexico nearly 50 years ago, very little is known about the ecology of these communities or the basic biology of the corals that produce them. Say that one of the primary objectives of the Expedition is to measure physical conditions that may determine whether deepwater coral reefs can grow in a specific location. Briefly discuss why scientists believe currents and sedimentation may be important physical conditions: most corals are filter-feeders, and excessive sediment may interfere with feeding activities (you may want to show images

of coral polyps to help make this point). Currents could help sweep sediment away from corals, but branching corals (such as *Lophelia sp.*) may be broken if water movement is too strong. Tell students that scientists on the *Lophelia II* 2009 Expedition plan to leave instruments that will measure currents and sedimentation in selected locations for an entire year, and describe the mooring system (Figure 1) that will be used to keep the instruments in place.

3. Give each student group a copy of the “Density and Buoyancy Inquiry Guide” and a collection of objects whose density and buoyancy are to be determined. If necessary, explain how to use the balance, where students are to obtain water, and how they should dispose of wastewater. Now, on with the Inquiry!
4. Lead a discussion of students’ results. In Part A of the Inquiry Guide, students should realize that they need to know mass and volume to find the density of an object. Since the volume of many substances change in response to temperature, it is also true that the density of an object also depends upon temperature. But temperature changes usually have very small effects on density compared to the effects of changing mass and volume. Students should also observe that objects that float have lower densities than objects that sink.

In Part B, students should realize that increasing the volume of an object will increase the volume and weight of fluid displaced when the object is immersed, and thus will increase the buoyant force acting on the object.

Most science standards do not expect elementary students to distinguish between mass and weight, but middle school (grades 6-8) students are expected to make this distinction. These concepts can be easily confused when dealing with density and buoyancy, because when students use a balance to determine mass they are actually measuring weight (mass multiplied by the force of gravity). This works out because the balance is calibrated to take gravity into account, but under zero gravity conditions the balance would not give an accurate estimate of mass. So, if we want to calculate the buoyant force acting on an object based on the weight of displaced fluid, we have to use units of weight such as pounds. If we want to use metric units of force (Newtons) we have to multiply the mass of the displaced fluid (in kg) by the acceleration of gravity (about  $9.81 \text{ m/sec}^2$ ). Since these metric units, as well as the concepts of gravitational acceleration, are usually taught in higher grade levels, we do not have students calculate actual buoyant force in this lesson. But if students discuss buoyant force in terms of “grams” or “kilograms,” it is important to remind them that these are units of mass and that buoyancy involves units of weight.

These considerations are not a problem for the "Design" portion of Part B, because the problem uses weight units (pounds). To calculate the minimum diameter for a plastic sphere that will displace enough water to generate a buoyant force of 600 lb:

1. Calculate the volume required to displace 600 lb of water. (One cubic inch of water weighs approximately 0.036127 lb.):

$$600 \text{ lb} \div 0.036127 \text{ lb/cubic inch} = 16,608 \text{ cubic inches}$$

2. Calculate the radius of a sphere with this volume:

(a)  $\frac{4}{3} \pi r^3 = 16,608 \text{ cubic inches}$

(b)  $r^3 = 16,608 \text{ cubic inches} \div \frac{4}{3} \pi$

(c)  $r^3 = 16,608 \text{ cubic inches} \div 4.1888$

(d)  $r^3 = 3,964.9 \text{ cubic inches}$

(e)  $r = 15.827 \text{ inches}$

3. Calculate the diameter of the sphere:

$$D = 2r = 2 (15.827 \text{ inches}) = 31.654 \text{ inches}$$

Discuss other factors that might influence this calculation. Temperature could have a relatively minor effect, as discussed above. Pressure would be a much more serious consideration, since at depths of 400 m to 1500 m the pressure would be roughly 40 to 150 times greater than surface pressure. This presents serious design considerations, since there would be a large pressure difference between the inside and outside of the sphere if the sphere contained air at normal atmospheric pressure. This problem can be reduced by filling the sphere with something relatively incompressible but lighter than water; the floats used in moorings for the *Lophelia II* 2009 expedition are filled with syntactic foam encased in high-strength polyethylene shells. Syntactic foams contain hollow particles called microballoons surrounded by a hard material such as epoxy or ceramics.

Salinity also affects buoyancy, and some of your students have probably found that it is easier to float in seawater than in freshwater. The reason, of course, is that the density of seawater is greater than freshwater (at the same temperature); so the weight of seawater displaced by an object will be greater than the weight of freshwater displaced by the same object, and the resulting buoyant force is greater in seawater.

### The Bridge Connection

<http://www.vims.edu/bridge/> – Enter “buoyancy” in the search box to retrieve activities involving buoyancy and density.

### The “Me” Connection

Have students write a brief essay describing how being able to calculate buoyancy might be of personal benefit.

### Connections to Other Subjects

English/Language Arts, Mathematics

### Evaluation

Written reports and class discussions provide opportunities for assessment.

### Extensions

1. Have students visit <http://oceanexplorer.noaa.gov/explorations/09lophelia/welcome.html> to find out more about the *Lophelia* II 2009: Deepwater Coral Expedition: Reefs, Rigs, and Wrecks.
2. Visit the “Buoyancy Basics” Web site from NOVA (<http://www.pbs.org/wgbh/nova/lasalle/buoybasics.html>) for a brief tutorial and “buoyancy brainteasers.”
3. Visit the Exploratorium Exhibit & Phenomena Cross-Reference page (<http://www.exploratorium.edu/xref/phenomena/buoyancy.html>) for links to exhibits about buoyancy and Archimedes’ Principle.

### Multimedia Discovery Missions

<http://oceanexplorer.noaa.gov/edu/learning/welcome.html>  
Click on the links to Lessons 3, 5, and 6 for interactive multimedia presentations and Learning Activities on Deep-Sea Corals, Chemosynthesis and Hydrothermal Vent Life, and Deep-Sea Benthos.

### Other Relevant Lesson Plans from NOAA’s Ocean Exploration Program

#### Shipwreck Explorers

(PDF, 299 kb) (from the *Lophelia* II 2008 Expedition)

<http://oceanexplorer.noaa.gov/explorations/08lophelia/background/edu/media/shipwreck.pdf>

Focus: Marine archaeology (Physical Science)

In this activity, students use data about the location and types of artifacts recovered from a shipwreck site to draw inferences about the sunken ship and the people who were aboard.

**Entering the Twilight Zone**

(8 pages, 352k) (from the Expedition to the Deep Slope 2007)  
<http://oceanexplorer.noaa.gov/explorations/07mexico/background/edu/media/zone.pdf>  
Focus: Deep-sea habitats (Life Science)

In this activity, students will be able to describe major features of cold seep communities, list at least five organisms typical of these communities and infer probable trophic relationships within and between major deep-sea habitats. Students will also be able to describe the process of chemosynthesis in general terms, contrast chemosynthesis and photosynthesis, describe major deep-sea habitats and list at least three organisms typical of each habitat.

**Animals of the Fire Ice**

(5 pages, 364k) (from the Expedition to the Deep Slope 2007)  
<http://oceanexplorer.noaa.gov/explorations/07mexico/background/edu/media/animals.pdf>

Focus: Methane hydrate ice worms and hydrate shrimp (Life Science)

In this activity, students will be able to define and describe methane hydrate ice worms and hydrate shrimp, infer how methane hydrate ice worms and hydrate shrimp obtain their food, and infer how methane hydrate ice worms and hydrate shrimp may interact with other species in the biological communities of which they are part.

**A Piece of Cake**

(7 pages; 282kb PDF) (from the Cayman Islands Twilight Zone 2007 Expedition)  
<http://oceanexplorer.noaa.gov/explorations/07twilightzone/background/edu/media/cake.pdf>

Focus: Spatial heterogeneity in deepwater coral communities (Life Science)

In this activity, students will be able to explain what a habitat is, describe at least three functions or benefits that habitats provide, and describe some habitats that are typical of deepwater hard bottom communities. Students will also be able to explain how organisms, such as deep-water corals and sponges, add to the variety of habitats in areas such as the Charleston Bump.

**Deep Gardens**

(11 pages; 331kb PDF) (from the Cayman Islands Twilight Zone 2007 Expedition)

<http://oceanexplorer.noaa.gov/explorations/07twilightzone/background/edu/media/deepgardens.pdf>

Focus: Comparison of deep-sea and shallow-water tropical coral communities (Life Science)

In this activity, students will compare and contrast deep-sea coral communities with their shallow-water counterparts, describe three types of coral associated with deep-sea coral communities, and explain three benefits associated with deep-sea coral communities. Students will explain why many scientists are concerned about the future of deep-sea coral communities.

**Let's Make a Tubeworm!**

(6 pages, 464k) (from the 2002 Gulf of Mexico Expedition)

[http://oceanexplorer.noaa.gov/explorations/02mexico/background/edu/media/gom\\_tube\\_gr56.pdf](http://oceanexplorer.noaa.gov/explorations/02mexico/background/edu/media/gom_tube_gr56.pdf)

Focus: Symbiotic relationships in cold-seep communities (Life Science)

In this activity, students will be able to describe the process of chemosynthesis in general terms, contrast chemosynthesis and photosynthesis, describe major features of cold seep communities, and list at least five organisms typical of these communities. Students will also be able to define symbiosis, describe two examples of symbiosis in cold seep communities, describe the anatomy of vestimentiferans, and explain how these organisms obtain their food.

**What's In That Cake?**

(9 pages, 276k) (from the 2006 Expedition to the Deep Slope)

<http://oceanexplorer.noaa.gov/explorations/06mexico/background/edu/GOM%2006%20Cake.pdf>

Focus: Exploration of deep-sea habitats (Life Science)

In this activity, students will be able to explain what a habitat is, describe at least three functions or benefits that habitats provide, and describe some habitats that are typical of the Gulf of Mexico. Students will also be able to describe and discuss at least three difficulties involved in studying deep-sea habitats and describe and explain at least three techniques scientists use to sample habitats, such as those found on the Gulf of Mexico.



## Other Resources

*The Web links below are provided for informational purposes only. Links outside of Ocean Explorer have been checked at the time of this page's publication, but the linking sites may become outdated or non-operational over time.*

<http://oceanexplorer.noaa.gov> – Web site for NOAA's Ocean Exploration Program

<http://celebrating200years.noaa.gov/edufun/book/welcome.html#book> – A free printable book for home and school use introduced in 2004 to celebrate the 200th anniversary of NOAA; nearly 200 pages of lessons focusing on the exploration, understanding, and protection of Earth as a whole system

<http://www.pbs.org/wgbh/nova/lasalle/buoybasics.html> – “Buoyancy Basics” Web site from NOVA

[http://www.gomr.mms.gov/index\\_common.html](http://www.gomr.mms.gov/index_common.html) – Minerals Management Service Web site

<http://www.gomr.mms.gov/homepg/lagniapp/chemcomp.pdf> – “Chemosynthetic Communities in the Gulf of Mexico” teaching guide to accompany a poster with the same title, introducing the topic of chemosynthetic communities and other ecological concepts to middle and high school students

<http://www.gomr.mms.gov/homepg/lagniapp/lagniapp.html> – Kids Page on the Minerals Management Service Web site, with posters, teaching guides and other resources on various marine science topics

<http://www.coast-nopp.org/> – Resource Guide from the Consortium for Oceanographic Activities for Students and Teachers, containing modules, guides, and lesson plans covering topics related to oceanography and coastal processes

<http://cosee-central-gom.org/> – Web site for The Center for Ocean Sciences Education Excellence: Central Gulf of Mexico (COSEE-CGOM)

## National Science Education Standards

### Content Standard A: Science As Inquiry

- Abilities necessary to do scientific inquiry
- Understandings about scientific inquiry

### Content Standard B: Physical Science

- Properties and changes of properties in matter

**Content Standard C: Life Science**

- Populations and ecosystems

**Content Standard F: Science in Personal and Social Perspectives**

- Populations, resources, and environments

**Ocean Literacy Essential Principles and Fundamental Concepts**

**Essential Principle 5.**

**The ocean supports a great diversity of life and ecosystems.**

*Fundamental Concept c.* Some major groups are found exclusively in the ocean. The diversity of major groups of organisms is much greater in the ocean than on land.

*Fundamental Concept d.* Ocean biology provides many unique examples of life cycles, adaptations and important relationships among organisms (such as symbiosis, predator-prey dynamics and energy transfer) that do not occur on land.

*Fundamental Concept f.* Ocean habitats are defined by environmental factors. Due to interactions of abiotic factors such as salinity, temperature, oxygen, pH, light, nutrients, pressure, substrate and circulation, ocean life is not evenly distributed temporally or spatially, i.e., it is “patchy”. Some regions of the ocean support more diverse and abundant life than anywhere on Earth, while much of the ocean is considered a desert.

*Fundamental Concept g.* There are deep ocean ecosystems that are independent of energy from sunlight and photosynthetic organisms. Hydrothermal vents, submarine hot springs, and methane cold seeps rely only on chemical energy and chemosynthetic organisms to support life.

**Essential Principle 6.**

**The ocean and humans are inextricably interconnected.**

*Fundamental Concept b.* From the ocean we get foods, medicines, and mineral and energy resources. In addition, it provides jobs, supports our nation’s economy, serves as a highway for transportation of goods and people, and plays a role in national security.

*Fundamental Concept e.* Humans affect the ocean in a variety of ways. Laws, regulations and resource management affect what is taken out and put into the ocean. Human development and activity leads to pollution (such as point source, non-point source, and noise pollution) and physical modifications (such as changes to beaches, shores and rivers). In addition, humans have removed most of the large vertebrates from the ocean.

*Fundamental Concept g.* Everyone is responsible for caring for the ocean. The ocean sustains life on Earth and humans must live in ways that sustain the ocean. Individual and collective actions are needed to effectively manage ocean resources for all.

**Essential Principle 7.**

**The ocean is largely unexplored.**

*Fundamental Concept a.* The ocean is the last and largest unexplored place on Earth—less than 5% of it has been explored. This is the great frontier for the next generation’s explorers and researchers, where they will find great opportunities for inquiry and investigation.

*Fundamental Concept b.* Understanding the ocean is more than a matter of curiosity. Exploration, inquiry and study are required to better understand ocean systems and processes.

*Fundamental Concept c.* Over the last 40 years, use of ocean resources has increased significantly, therefore the future sustainability of ocean resources depends on our understanding of those resources and their potential and limitations.

*Fundamental Concept d.* New technologies, sensors and tools are expanding our ability to explore the ocean. Ocean scientists are relying more and more on satellites, drifters, buoys, subsea observatories and unmanned submersibles.

*Fundamental Concept f.* Ocean exploration is truly interdisciplinary. It requires close collaboration among biologists, chemists, climatologists, computer programmers, engineers, geologists, meteorologists, and physicists, and new ways of thinking.

**Send Us Your Feedback**

We value your feedback on this lesson.  
Please send your comments to:  
oceanexeducation@noaa.gov

**For More Information**

Paula Keener-Chavis, Director, Education Programs  
NOAA Ocean Exploration and Research Program  
Hollings Marine Laboratory  
331 Fort Johnson Road, Charleston SC 29412  
843.762.8818  
843.762.8737 (fax)  
paula.keener-chavis@noaa.gov

**Acknowledgements**

This lesson plan was produced by Mel Goodwin, PhD, The Harmony Project, Charleston, SC for the National Oceanic and Atmospheric Administration. If reproducing this lesson, please cite NOAA as the source, and provide the following URL: <http://oceanexplorer.noaa.gov>

## Big Enough

# Density and Bouyancy Inquiry Guide

### A. Density

*Background:* Density is a physical property of matter that is related to an object's mass (how "heavy" it is) and volume (the object's physical size). You know that a handful of styrofoam weighs much less than a handful of rocks. This is because the density of the styrofoam is less than the density of the rocks. Density is usually defined as "mass per unit volume," and the density of an object or substance is stated in "grams per cubic centimeter."

*Inquire:* Your task is to measure the density of objects in the collection provided by your teacher. What two properties of each object do you need to know to find the object's density?

---

---

Measure the mass of each object using a balance as directed by your teacher. Record these measurements on the data sheet.

Now measure the volume of each object. The easiest way to do this is to immerse the object in water in a graduated cylinder and measure the increase in water volume. Put water into a graduated cylinder so the cylinder is about half full. Record the volume of the water on the data sheet in the "Volume Without Object" column. Drop the object into the cylinder and record the new volume on the data sheet in the "Volume With Object" column. If the object floats, you will need to push it down with a piece of stiff wire until the object is completely submerged. Subtract "Volume Without Object" from "Volume With Object" and record the result in the "Object Volume" column.

Calculate the density of each object by dividing the mass by the volume, and record the results on the data sheet in the "Density" column. Hint: One milliliter is the same as one cubic centimeter.

Record the buoyancy of the object in the last column.

What do you notice about the density of objects that sink compared to objects that float?

---

---

---

---

---

---



## Big Enough

# Density and Bouyancy Inquiry Guide – continued

### B. Buoyancy

*Background:* Read the following explanation of Archimedes’ Principle:

The idea of buoyancy was summed up by a Greek mathematician named Archimedes: any object, wholly or partly immersed in a fluid, is buoyed up by a force equal to the weight of the fluid displaced by the object. Today, this definition is called Archimedes Principle.

Archimedes is considered one of the three greatest mathematicians of all time (the other two are Newton and Gauss). Archimedes was born in 287 B.C., in Syracuse, Greece. He was a master at mathematics and spent most of his time thinking about new problems to solve.

Many of these problems came from Hiero, the king of Syracuse. Archimedes came up with his famous principle while trying to solve this problem: The king ordered a gold crown and gave the goldsmith the exact amount of metal to make it. When Hiero received it, the crown had the correct weight but the king suspected that some silver had been substituted for the gold. He did not know how to prove it, so he asked Archimedes for help.

One day while thinking this over, Archimedes went for a bath and water overflowed the tub. He recognized that there was a relationship between the amount of water that overflowed the tub and the amount of his body that was submerged. This observation gave him the means to solve the problem. He was so excited that he ran naked through the streets of Syracuse shouting “I have found it!”. The goldsmith was brought to justice and Archimedes never took another bath...(just kidding!).

(from “Discover Your World with NOAA: An Activity Book;” <http://celebrating200years.noaa.gov/edufun/book/welcome.html>)

*Inquire:* If the volume of an object increases but the mass of the object does not change, how does this affect the buoyant force acting on the object when it is immersed in a fluid?

---

---

---

---

---

---

---

---

## Big Enough

### Density and Bouyancy Inquiry Guide – continued

*Apply:* Scientists on the *Lophelia II* 2009: Deepwater Coral Expedition: Reefs, Rigs, and Wrecks want to make measurements of currents and sedimentation at several deep-ocean sites for an entire year. To make these measurements, scientists will attach measuring instruments to a mooring system that will keep the instruments in a fixed location at a specific depth. Because the sites are offshore and in deep water (400 m to 1500 m), the mooring system must be heavy enough and strong enough to withstand strong ocean currents, and must also have a float with sufficient buoyancy to keep the instruments and mooring cable suspended above the seafloor. Figure 1 shows the main parts of the mooring system.

**Figure 1:**  
**Mooring System**

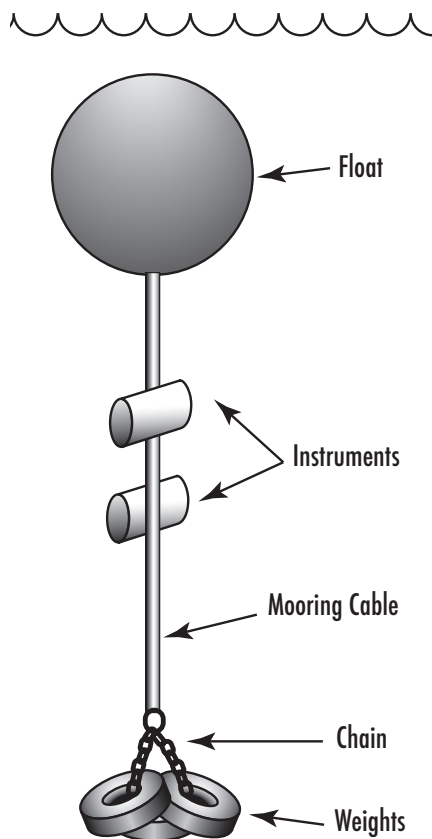

The anchor of the mooring system is made of railroad freight car wheels, each of which weighs about 700 lb. The anchor is attached to a length of 3/8" chain, which is attached to a 1/4" diameter stainless steel cable that serves as the mooring wire. The other end of the mooring wire is connected to a float that provides a buoyant force of 600 lb. What is the minimum diameter for a plastic sphere that will have this buoyancy?

*Hints:* The formula for the volume of a sphere is  $\frac{4}{3} \pi r^3$ . One cubic inch of water weighs approximately 0.036127 lb.